



MASTER & DYNAMIC

MW60 WIRELESS OVER EAR HEADPHONES - MODEL NO. MW60S2, Silver Metal / Brown Leather

THE FINEST MATERIALS

- 1 Cowhide
- 2 Lambskin
- 3 Folding Hinge
- 4 Brass Bearings
- 5 All Wires Hidden
- 6 Stainless Steel with PVD Coating
- 7 Brass Bearings
- 8 Removable Ear Pads: Memory Foam Wrapped in Lambskin
- 9 Milled Aluminum Throughout: Anodized Finish
- 10 Enamel Filled Logo
- 11 16hr Lithium-ion Battery
- 12 Bluetooth® 4.1 supporting AptX™, AAC, MP3, SBC
- 13 Omnidirectional Mic
- 14 Micro USB Port
- 15 Cowhide
- 16 Passive Audio Port



IT'S ALL IN THE DETAILS



Laser Etched Earcup Ear Pad



45mm Custom Neodymium Drivers

ACCESSORIES

- Protective Carrying Case
- USB Charging Cable
- 1.25m Standard Audio Cable
- 3.5mm/6.3mm Gold-Plated Adapter
- Leather Storage Box



MW60 WIRELESS OVER EAR HEADPHONES
MODEL NO. MW60G1
 Gunmetal / Black Leather



MW60 WIRELESS OVER EAR HEADPHONES
MODEL NO. MW60B1
 Black Metal / Black Leather

- Connectivity Status
- Battery Status
- Pairing
- On
- Off



FOLDS FOR STORAGE



TACTILE CONTROLS

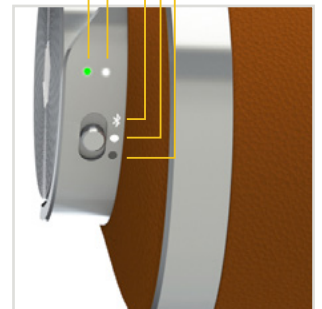

INTUITIVE INTERFACE